

# DWD XP

## Drawer H95

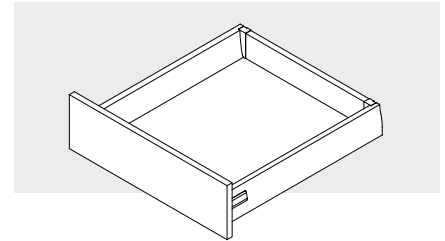

- Fully synchronised slide technology without mid-way knock
- Excellent running characteristics
- Maximum stability
- Minimal drawer deflection
- Integrated side and eccentric height adjustment including locking screw
- Stable front holder
- Removal and transport protection
- Bottom panel machining not required
- Width of bottom and back panel is the same



### ORDER INFORMATION

1 DWD XP drawer sides H95 incl. cover caps			
NL	Aluminium metallic	White	Stainless steel
275	F090075281	F090075282	F090075284
300	F090077343	F090077344	-
350	F090075285	F090075286	F090075288
400	F090075289	F090075290	F090075292
450	F090075293	F090075294	F090075296
500	F090075297	F090075298	F090075300
550	F090075301	F090075302	F090075304
600	F090075305	F090077345	-
650	F090075308	F090077346	-

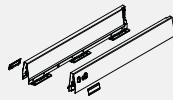

2 DWD XP full extension slide with Soft-close			
NL	40 kg	60 kg	
275	F091075473	-	
300	F091077407	-	
350	F091075474	-	
400	F091075475	-	
450	F091075476	F091075528	
500	F091075477	F091075529	
550	F091075478	F091075530	
600	-	F091075531	
650	-	F091075532	

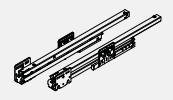

3 Clip set for wooden back panel H86			
	Aluminium metallic	White	Nickel-plated
	F092082925	F092082928	F092082931



4 Front holder			
	For screw fixing	For press fitting	Expansion dowel
	F092083116	F092083117	F092083119

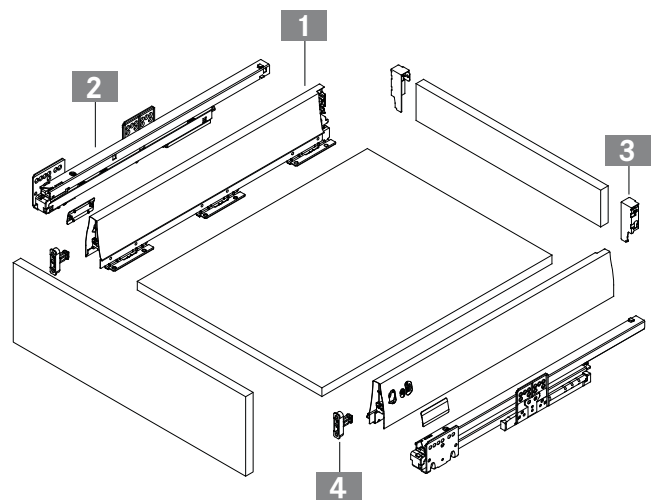
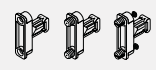

DWD XP Magic Sorto	90
Technical information	72

DWD XP Tipmatic Plus	70
Assembly technology	100

DWD XP Sensomatic	111
Accessories	92

INSTALLATION INFORMATION

All dimensions in millimetres

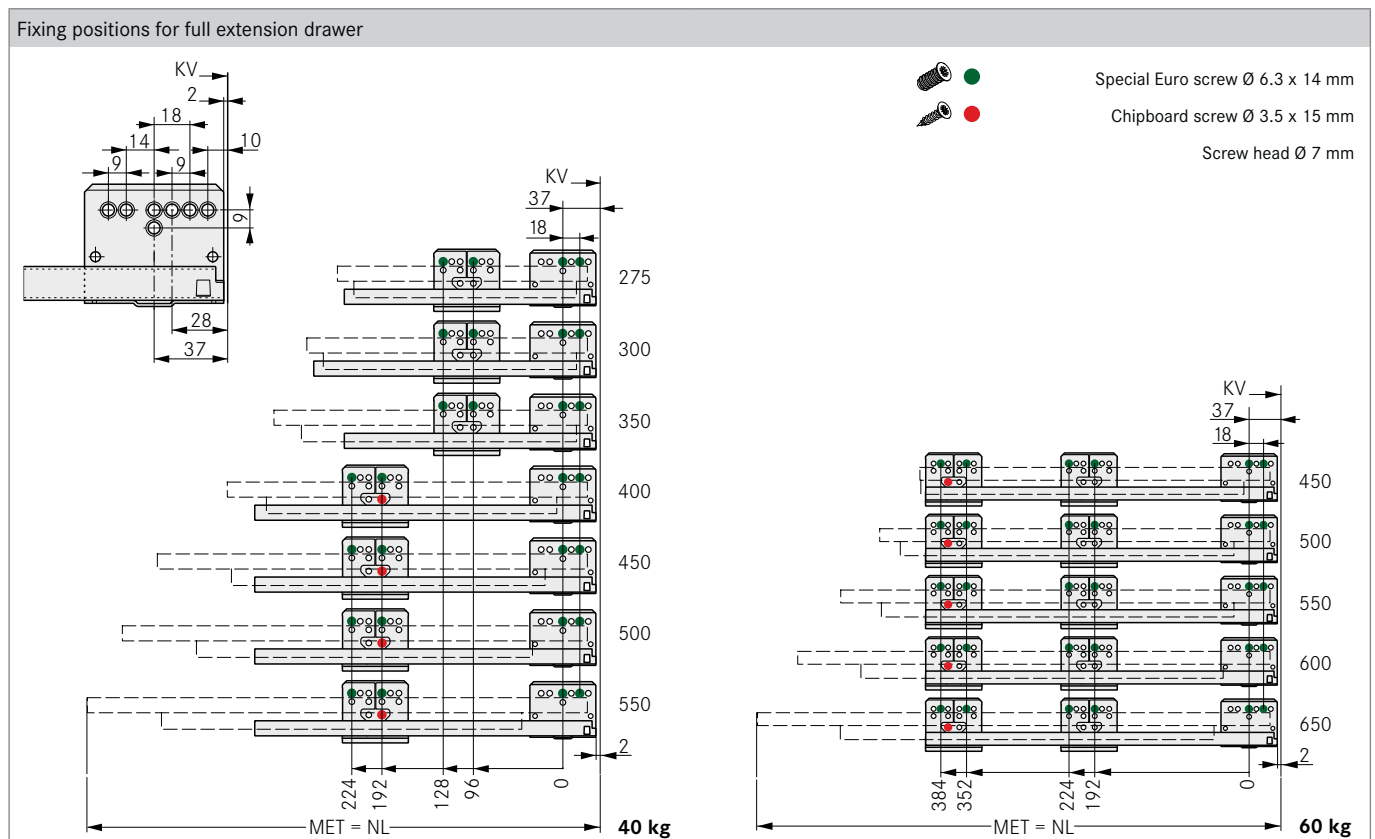
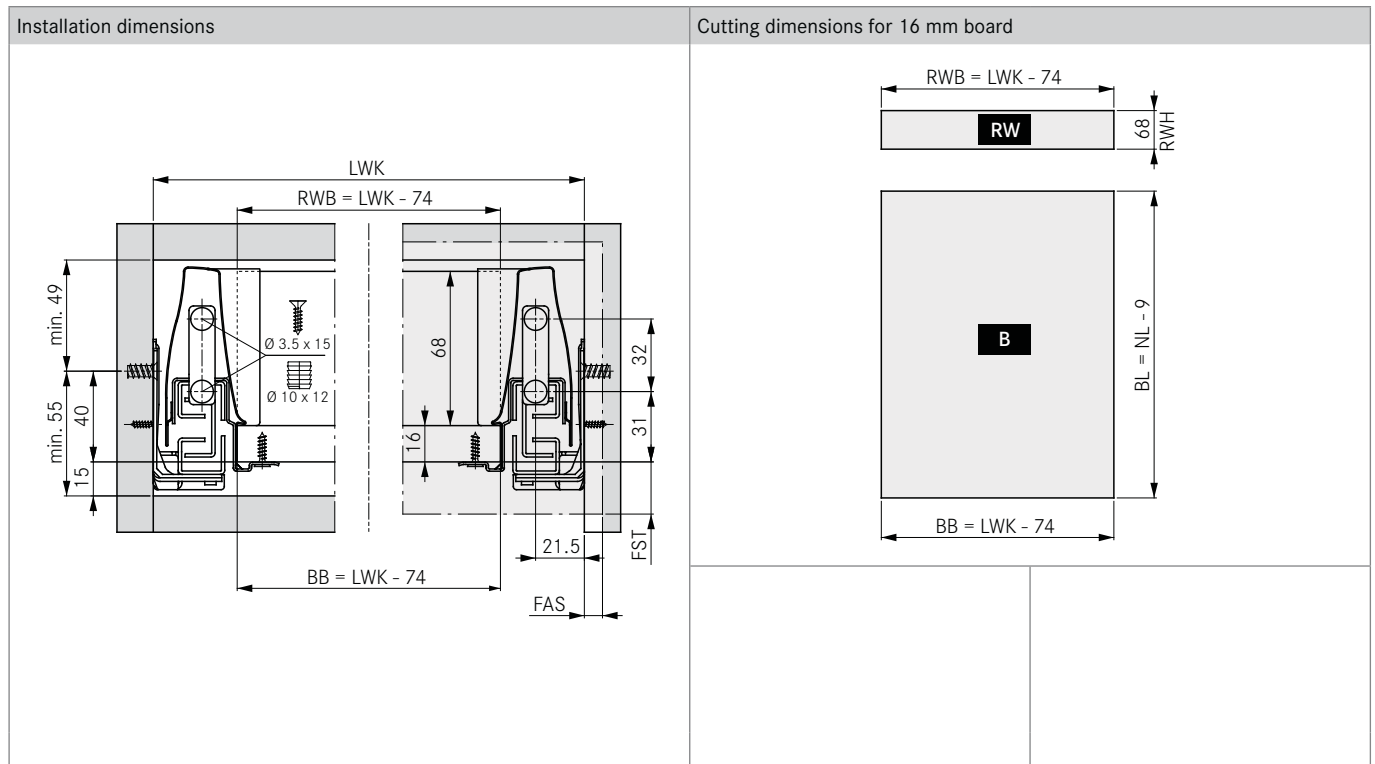

LEGEND

B	Bottom panel	FST	Front overlay	NL	Nominal length
BB	Bottom panel width	KV	Front edge of cabinet	RW	Back panel
BL	Bottom panel length	LWK	Inside cabinet width	RWB	Width of back panel
FAS	Front overlay, side	MET	Minimum installation depth	RWH	Height of back panel